

SIGNATURE HANDLE

TECHNICAL SPECIFICATION

Product Material Specifications:

- Metal Parts – Zinc Alloy and Aluminium Alloy
- Plastic Parts – ABS-757 Resin

Testing:

- Corrosion resistance to BS EN 1670 Grade 5
- Cycle Tested to 10,000 cycles under operational load

Colours: White, Black, Gold, Chrome & Titanium

Locking Options: Key Locking / Non-Locking Egress Plug

Spindle Length: 43mm

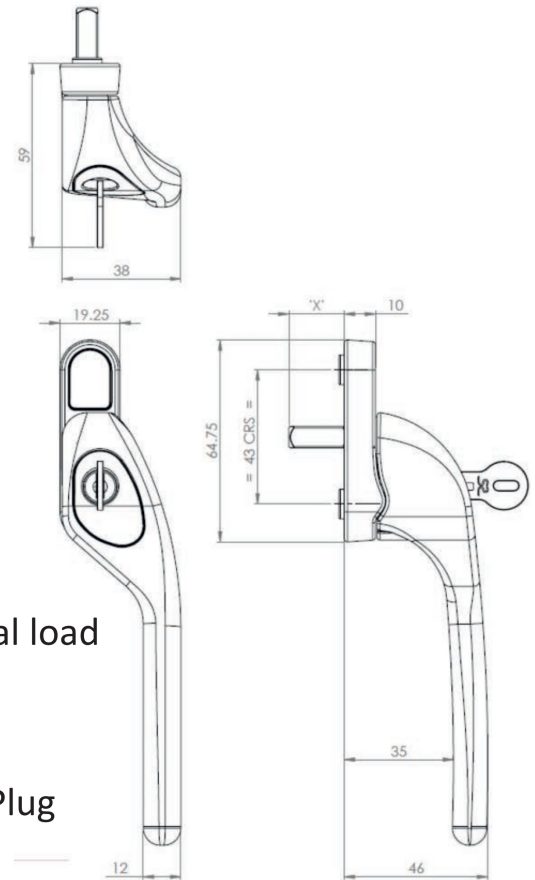

Right Hand Variant Shown



Huxley Close | Park Farm South | Wellingborough | Northamptonshire | NN8 6AB
T: 01933 674880 F: 01933 678635 E: info@emplas.co.uk www.emplas.co.uk

Registered in England No 1882731



ISO 14001:2004
EMS 566166

KM 594781

BS OHSAS 18001:2007
OHS 566161

PAS24:2012
KM 501328

PAS24:2012
KM 33513

PAS99:2012
IMR 566162

ISO 9001:2008
FM 12731

PAS24:2012
KM 597764

Official Police Security Initiative